



Lithium-ion Battery

DATA SHEET

Battery Model: **LIR2025**

Prepared	Authorized	Approved
Zhe Hao, Wei	Feng , Li	Ji de, Wong

Manufacturer: EEMB Co., Ltd.

Website: <http://eemb.com>

This Specification describes the requirements of the lithium ion rechargeable battery supplied by EEMB Co., Ltd.

1.0 BASIC CHARACTERISTICS

1.1	Battery Type	LIR2025	
1.2	Nominal Voltage	3.6V	
1.3	Nominal Capacity	30±2mAh	
1.4	Maximum Capacity	32mAh	
1.5	Dimension	diameter	20.0mm _{-0.2}
		Height	2.5mm _{+0.3}
1.6	Weight	2.3±0.3g	

2.0 Battery Characteristics

2.1 Testing Conditions

Temperature: 20±1°C

Relative Humidity: 75±5%RH

Atmosphere pressure: 1atm

2.2 Standard Charge/Discharge Characteristics

The test should be conducted under the condition below:

In a temperature of 20±5°C, CC charge 0.2CmA / voltage up to 4.20V; Then CV charge. Terminate charging when the charging current value is less than 0.05CmA. Rest for no more than 10 minutes, Discharge CC at 0.2CmA to 2.75V.

2.3 Fast Charge/Discharge Characteristics

Temperature 20±5°C, CC charge at 1CmA to 4.20V; turn to CV charge; Terminate charging when the charging current value is less than 0.05CmA, rest for no more than 10 minutes, then at 1CmA CC discharge to 2.75V.

2.4 Temperature Characteristics

Working temperature range: - 20°C—60°C

2.5 Storage temperature: 20°C±1

Note: Any representations in this brochure concerning performance, are for informational purposes only and are not construed as warranties either expressed or implied, of future performance.

<http://eemb.com> global@eemb.com

3.0 Charging Characteristics at various currents

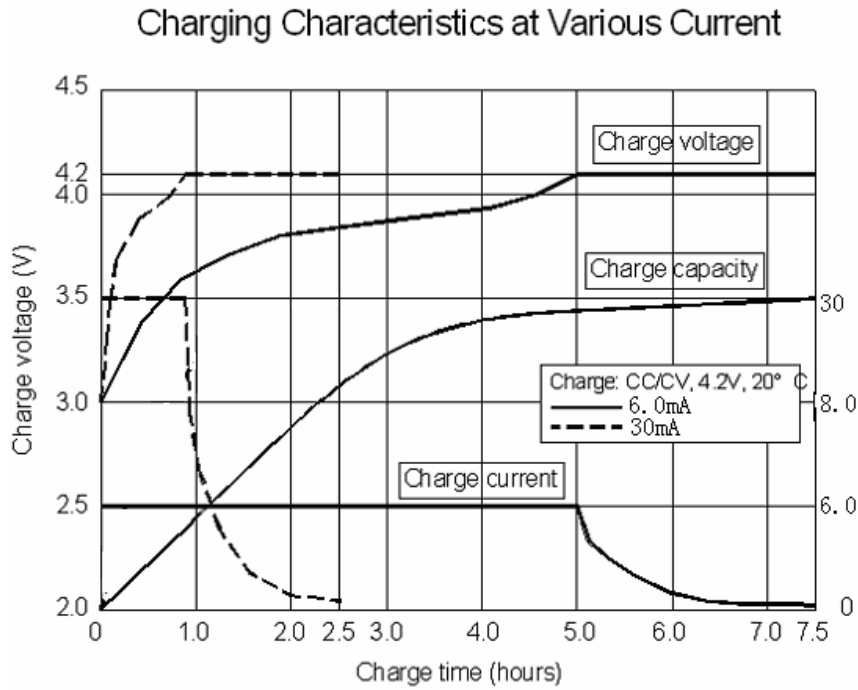

4.0 Discharge Characteristics at various currents

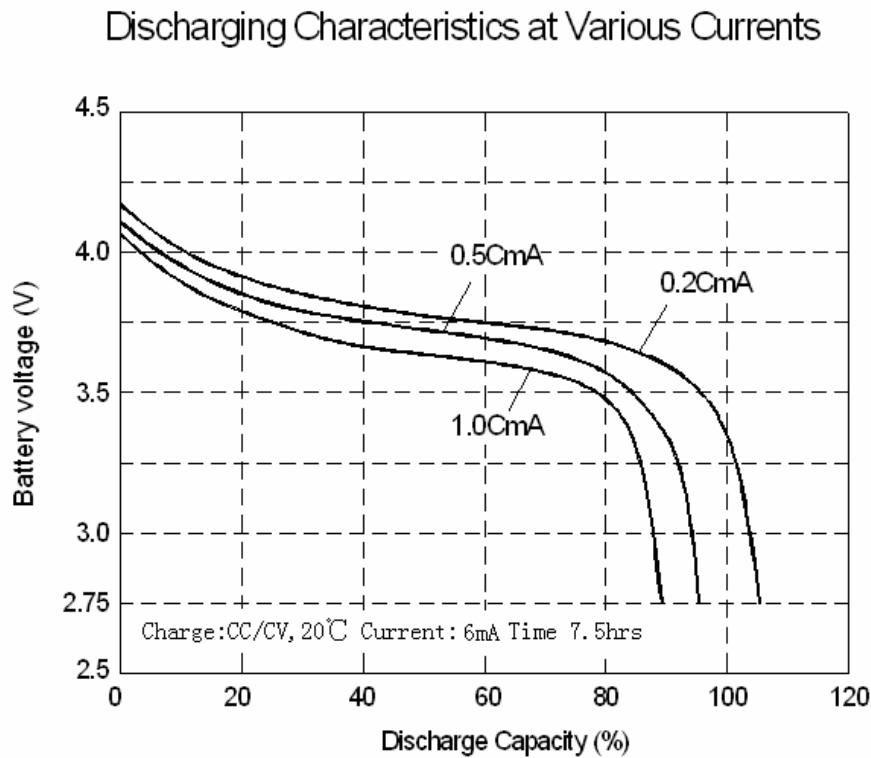

Note: Any representations in this brochure concerning performance, are for informational purposes only and are not construed as warranties either expressed or implied, of future performance.
<http://eemb.com> global@eemb.com

5.0 Discharging Characteristics at various Temperatures

Discharging Characteristics at Various Temp.

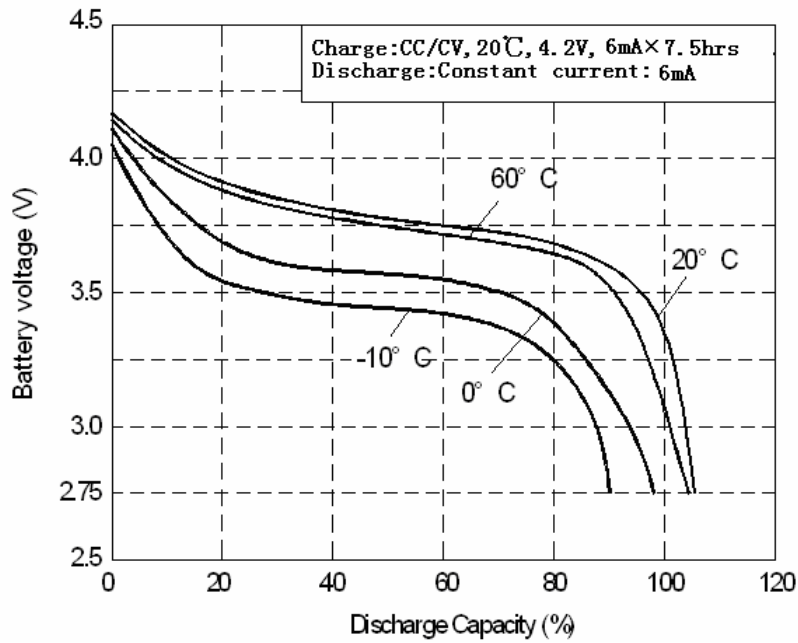

6.0 Storage Characteristics

Storage Characteristics

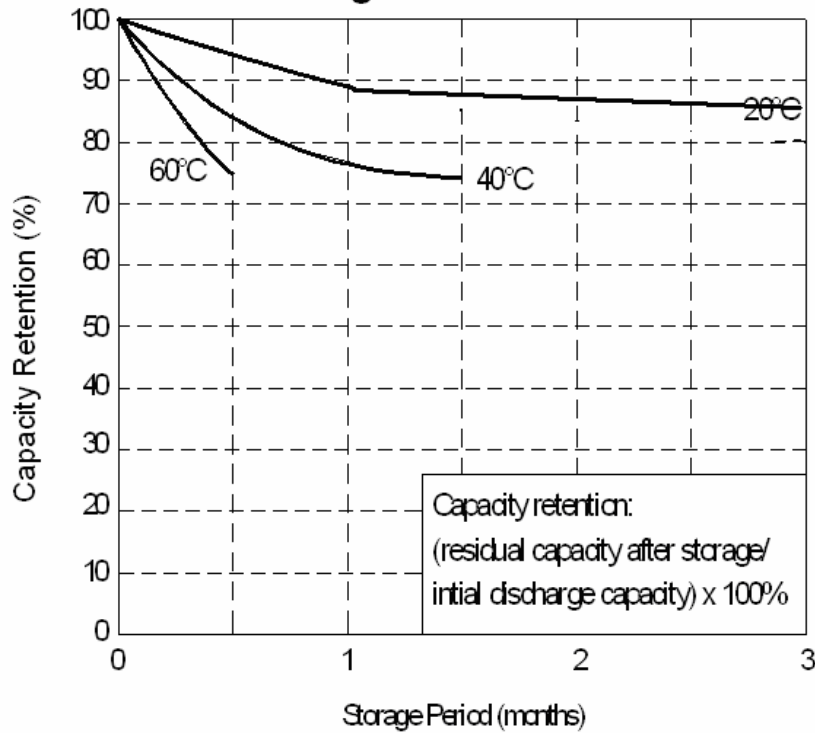

Note: Any representations in this brochure concerning performance, are for informational purposes only and are not construed as warranties either expressed or implied, of future performance.

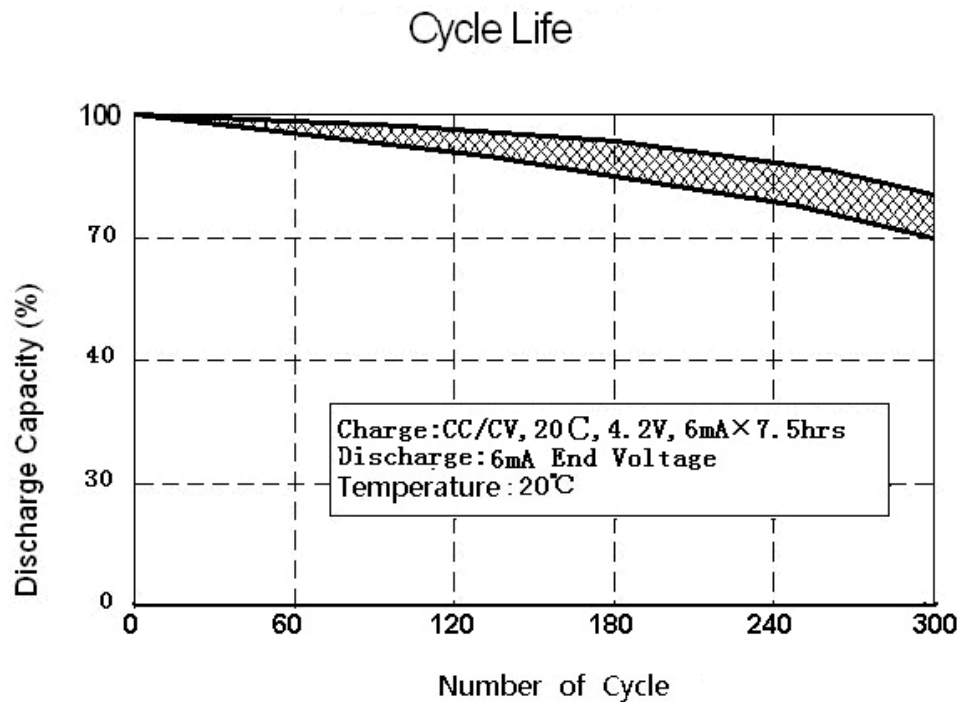
7.0 Cycle Life Chart

8.0 General Features
8.1 Long Cycle Life

Under normal usage, the cycle life of the battery can be ≥ 300 circles while with capacity $\geq 80\%$

8.2 High Power Density

High power density makes the battery light in weight and small in dimension. It can be used in small devices.

8.3 Safe and Reliable

No floating metal lithium assures a safer usage.

8.4 High working voltage

Working voltage is up to 3.6V, approx. 3 times of the voltage of NI-MH or NI-CD, which reduces the quantity of the battery needed in certain application.

8.5 No memory effect

No memory effect assures a constant maximum application.

8.6 Low self-discharge rate: $\leq 5\%$ /month
8.7 Good Consistency

Good consistency is showed in battery capacity, internal resistance, discharge platform and capacity retention. A strict complete internal quality control is subject to the ISO9000 system in the company's production.

Note: Any representations in this brochure concerning performance, are for informational purposes only and are not construed as warranties either expressed or implied, of future performance.

<http://eemb.com> global@eemb.com

9.0 BATTERY DIMENSION

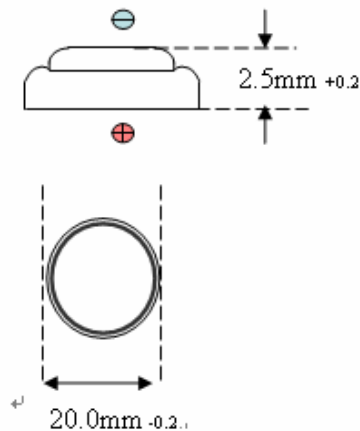

10.0 Important Notes

Keep away from source of fire and/or heat.

Do not disassemble battery and/or battery pack.

Do not connect the positive and negative pole directly using conductive metal; avoid short circuit.

Do not put the battery into water or damp it.

Do not cut the battery.

Do not strike or needle the battery.

Charge the battery using specified chargers.

Do not solder the battery directly.

Observe the correct polarity (+/-)

Do not use the battery in un-specified application.

Do not mix the battery in usage with other types of battery.

Read the instruction manual carefully before use.

When the battery is used on load, it is recommended to design a charge/discharge protection circuit for the battery.

When the battery is stored and not used under room temperature for over 6 months, it needs to be recharged by the procedure below: Discharge by CC mode at 0.2CmA to 2.75V, then rest for 5 minutes, Charge by CC mode at 0.2CmA to 4.20V limit, then change to CV charge mode, Cut off the charge when the charging current is less than 0.05CmA.

! Special Notice

Keep the cells in **50% charged state** during long period storage. We recommend to charge the battery up to 50% of the total capacity every 3 months after receipt of the battery and maintain the voltage 3.6~4.0V. And store the battery in cool and dry place.

Note: Any representations in this brochure concerning performance, are for informational purposes only and are not construed as warranties either expressed or implied, of future performance.

<http://eemb.com> global@eemb.com